

# InterFlo™

THE CONVENIENT DRINKING WATER SOLUTION



## OWNER'S MANUAL & INSTALLATION GUIDE

Models: IF-14, IF-15



Congratulations on choosing a superior water filter for your tap!  
Use this guide to attain the maximum benefit from your  
new cartridge system.

As an owner, you may find the first few pages to be the most  
helpful in solving your needs.

If you have trouble with the operation of your Interflo™ water filter,  
please contact your local water treatment dealer.

---

## CONTENTS

Box Contents .....	1
Installation Guide .....	2-3
Care & Maintenance / Performance Data .....	4-5
Warranty .....	Rear Cover

# BOX CONTENTS

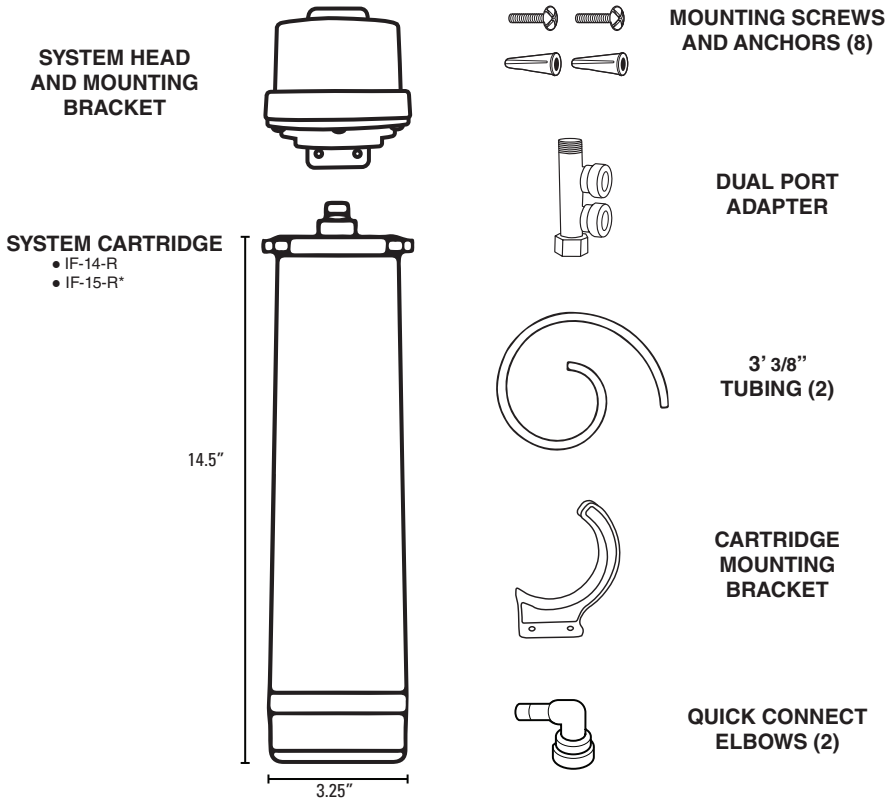

## TOOLS RECOMMENDED FOR INSTALLATION:

- Variable speed drill with 7/32" bit
- Adjustable wrench
- Measuring tape
- Level
- Phillips head screwdriver
- Pencil

*Note: We recommend using an approved or certified professional if drilling is required.*

The installation instructions on the following pages detail a standard installation on a main cold water faucet line. Due to the nature of the filtration block contained in the cartridge, the application of the InterFlo cartridge may affect the pressure and flow rate of the main cold water faucet line on which it is installed.

In instances where pressure and flow rate drops must be avoided, it is recommended that the InterFlo cartridge be installed and connected to a separate faucet. Please discuss options with your water treatment dealer to find the solution that is best for you.

*\*Not certified by IAPMO R&T*

# INSTALLATION GUIDE

## INSTALLATION OPTIONS

1. Vertical
2. Horizontal wall mount
3. Horizontal floor mount

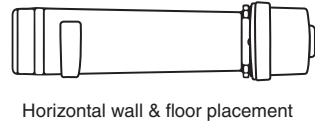

## INSTALLATION STEPS

- 1 Attach System Head to Cartridge to help determine under sink placement.

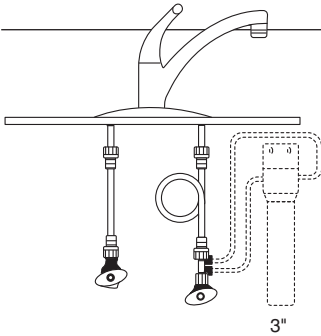

- 2 Locate a suitable area under the sink to mount the system, noting that at least three (3) inches of clearance from the base of the cartridge is needed for easy cartridge replacement. The System Head must be installed less than three (3) feet from the cold-water inlet valve.

- 3 After determining placement, remove Cartridge from System Head. Place System Head in desired mounting location and use a level and a pencil to mark all four (4) screw holes.

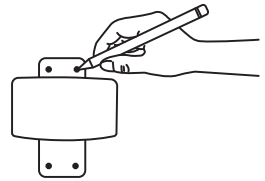

- 4 After penciling in the mounting placement, use a 7/32" drill bit to drill holes for plastic anchors. Carefully tap anchors into the drilled hole with a hammer.

- 5 Using a Phillips head screwdriver, mount the System Head and Cartridge Mounting Bracket using the provided screws. Ensure the bracket is mounted toward the end of the system sump for maximum support.

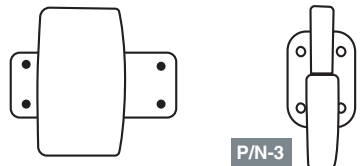

P/N-3

- 6** Place Cartridge into bracket and connect to System Head. Twist to lock into place.

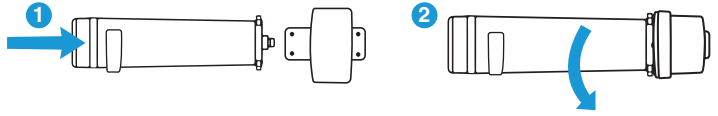

- 7** Turn off cold water supply by hand-rotating the shutoff handle until fully closed. Using an adjustable wrench, disconnect the cold water line. Attach Dual Port Adapter to shutoff valve and re-attach cold water line to the Dual Port Adapter.

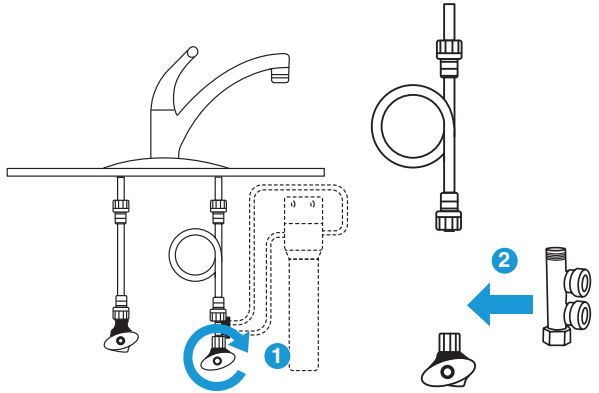

- 8** Connect 3/8" tubing to the bottom port. Measure tubing to system inlet (marked "IN") and cut to length. Repeat this step for the top port and outlet (marked "OUT").

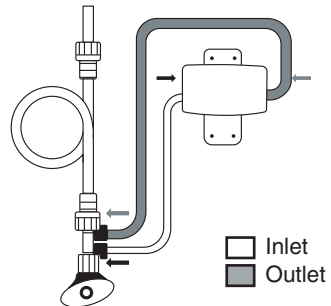

- 9** Use 3/8" quick connect elbows, if necessary.

- 10** Once tubing is installed, turn on COLD water kitchen faucet. With faucet on, slowly turn on the cold water supply.

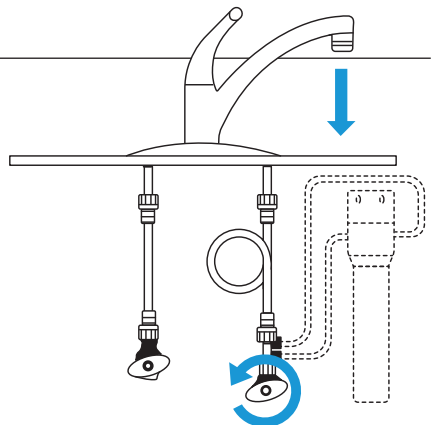

- 11** Flush cartridge for 15 minutes or until water is clear of carbon fines.

# CARE & MAINTENANCE / PERFORMANCE DATA

## IF-14 (100327665)

Replacement cartridge IF-14-R (100313684)

Rated service flow 2.0 gpm (7.57lpm)

Max capacity 7900 gallons (29,904 l)

Min working pressure 10 psi (137.85 kph)

Max working pressure 125 psi (551.58 kph)

Min operating temperature 35 °F (4.44 °C)

Max operating temperature 100 °F (32.22 °C)

To clean your filter unit, wipe down the exterior with a damp cloth.

### Safeguards

- Use only cold water with filter.
- If you experience a hose connection leak, disconnect and re-seat the hose.

## PERFORMANCE DATA SHEET FOR THE INTERFLO™ WATER FILTER

Models	Replacement	Operating pressure range	Rated capacity	Operating temp. range	Rated flow
IF-14 (100327665)	IF-14-R (100313684)	10-125 psi 68.95-861.8 kPa	7900 gallons 29,904 liters	35-100 F 1.66-37.78 C	2.0 gpm 7.57 lpm v

Testing Performed under NSF/ANSI Standards 42, 53, and 401 in accordance with the California Department of Health Services Drinking Water Treatment Device Program. This system has been tested according to NSF/ANSI 42, 53, and 401 for reduction of the substances listed below. The concentration of the indicated substances in water entering the system was reduced to a concentration less than or equal to the permissible limit for water leaving the system, as specified in NSF/ANSI 42, 53, and 401.

NSF/ANSI 42	REDUCTION REQUIREMENT	OVERALL % REDUCTION	RESULTS
Chlorine Reduction, Free Available	≥ 50%	94.8%	Pass
Particulate Reduction (Class I particles .5 µm to 1 µm)	85%	99.2%	Pass

NSF/ANSI 53	REDUCTION REQUIREMENT	OVERALL % REDUCTION	RESULTS
Cyst Live Cryptosporidium & Giardia	99.95%	> 99.99%	Pass
Lead Reduction pH 6.5	<5 µg/l	> 99.7%	Pass
Lead Reduction pH 8.5	<5 µg/l	> 99.2%	Pass

NSF/ANSI 401	MAX. PERMISSIBLE PRODUCT WATER CONCENTRATION	REDUCTION REQUIREMENT	OVERALL % REDUCTION	RESULTS
Microplastics (particles 0.5 to <1 µm)	At least 10,000 particles/ml	≥ 85%	99.2%	Pass

 Filter is only to be used with cold water.

 Systems certified for cyst reduction may be used on disinfected waters that may contain filterable cysts.

 Filter usage must comply with all state and local laws.

 Read owner's manual for general installation conditions and needs, as well as manufacturer's limited warranty.

 Testing was performed under standard laboratory conditions, actual performance may vary.

- All contaminants reduced by this filter are listed.
- Not all contaminants listed may be present in your water.
- Does not remove all contaminants that may be present in tap water.



System Certified by IAPMO R&T against NSF/ANSI Standards 42, 53, 372, 401, and CSA B 483.1. Please refer to Performance Data Sheet for specific contaminant reductions.



**Do not use with water that is microbiologically unsafe or of unknown water quality without adequate disinfection before or after the system. Systems certified for cyst reduction may be used on disinfected waters that may contain filterable cysts.**

# CARE & MAINTENANCE / PERFORMANCE DATA

## IF-15 (100340563)

Replacement cartridge IF-15-R (100340562)

Rated service flow 1.67 gpm (6.32 lpm)

Max capacity 7200 gallons (27,254 l)

Min working pressure 30 psi (206.843 kph)

Max working pressure 125 psi (551.58 kph)

Min operating temperature 35 °F (4.44 °C)

Max operating temperature 100 °F (32.22 °C)

Reduces: **Taste and Odor**

The IF-15 cartridge system has not been tested and certified for contaminant removal.

## IF-15 Features

The IF-15 filtration cartridge for the InterFlo system reduces taste and odor problems, such as chlorine.

The InterFlo system head is a universal match to all versions of filter cartridges available, making it easy to change cartridges without needing to adjust for form and fit.

## Installation and Operation Tips

- Install vertically, allowing for 2.5" clearance below the cartridge for easy replacement.
- Prior to installation, flush cartridge by running water through filter for five minutes.
- Change cartridge every six months, when capacity is reached, or when pressure falls below 10 psi.

# LIMITED 1 YEAR WARRANTY

## WHAT IS COVERED:

This warranty covers defects in materials or workmanship in manufacturing of your InterFlo drinking water filter system, except as provided below.

## FOR HOW LONG:

This warranty runs for 365 days from the date of purchase by a consumer ("Warranty Period").

## WHAT IS NOT COVERED:

This warranty does not cover filter cartridges and any products that were not installed in compliance with the instructions or that have been abused or operated incorrectly. The limited warranty stated herein is in lieu of any and all warranties, express or implied, whether written or oral, including but not limited the implied warranties of fitness for a particular purpose or the implied warranty of merchantability. The manufacturer shall not be liable for any incidental, consequential, special or contingent damages arising directly or indirectly from any defect or the use of the system. Owner shall be responsible for all labor and any other expenses related to the removal, repair or installation of the filtration system or any component part. Finally, this warranty is voided if the product is used with parts that are not genuine manufacturer parts.

This includes, but is not limited to: replacement filters, faucets, and diverter valves.

## RETURN POLICY ON DEFECTIVE UNITS:

All defective parts must be returned to your dealer, along with the equipment serial number and date of original installation. Defective parts will be sent back to the manufacturer with a PREPAID label and replacement parts will be returned to the customer by FREIGHT COLLECT.

## HOW STATE LAW APPLIES:

Some states do not allow limitations on how long an implied warranty lasts or the exclusion or limitation of incidental or consequential damages, so the above limitations and exclusion may not apply to you. This warranty gives you specific legal rights, and you may also have other rights which vary from state to state.

## FURTHER EXCLUSIONS AND LIMITATIONS ON WARRANTY:

This warranty is null and void unless the InterFlo cartridge system was purchased and installed from an approved dealer. No dealer, agent, representative, or other person is authorized to extend or expand this limited warranty

# InterFlo™

*InterFlo is a trusted brand distributed exclusively through an authorized network of water treatment professionals*

*Please contact your local installing dealer for additional support or to order replacement cartridges.*



System Certified by IAPMO R&T against NSF/ANSI Standards 42, 53, 372, 401, and CSA B 483.1. Please refer to Performance Data Sheet for specific contaminant reductions.

A. O. Smith Corporate | 11270 West Park Place, Suite 170 | P. O. Box 245008  
Milwaukee, WI 53224 | [www.aosmith.com](http://www.aosmith.com)